

# **DETECTION AND PREVENTION OF VAMPIRE ATTACKS IN NETWORK ENVIRONMENT**

*Amit Sharma*

*Assistant Professor*

*Apeejay Institute of Management Technical Campus (APJIMTC)*

*Jalandhar, Punjab, India*

Abstract— Wireless Sensor Networks (WSNs) in this day and age are the method for correspondence. These contain hubs that go about as transmitter and collectors are inclined to various assaults prompting to various sorts of misfortunes. The asset exhaustion assault that is gotten vampire assault empties out the vitality out of the hubs abandoning them futile. These assaults are convention consistent, they are anything but difficult to execute. Since they are orthogonal in nature they can without much of a stretch barge in into any steering convention. They influence the whole network bringing on substantial loss of vitality. The proposed strategy distinguishes the nearness of vampire assault and the reenactment comes about demonstrate the vitality utilization for every situation.

*Keywords – Vampire Attack, Network Security, Wireless Systems*

## **INTRODUCTION**

A wireless sensor network (WSN) comprises of spatially conveyed self-ruling sensors. Which are utilized to screen physical or even ecological conditions. The Conditions are temperature, sound, weight, and so forth. They too helpfully go their information through the network to a fundamental area. The cutting edge networks are bidirectional, which moreover empowering control of tactile exercises. The outline

and advancement of wireless sensor networks were roused by military applications, for example, front line reconnaissance. Presently, these networks are utilized as a part of numerous ventures and shopper applications, as modern process checking and control, wellbeing checking, and some more.

The WSN is made of "hubs" - from two or three to numerous bunches of or maybe thousands, wherever every hub is associated with 1 (then again ordinarily a few) sensors. Each such detecting component network hub has by and large many parts: a radio handset with an inside partner relationship to an outside receiving wire, a microcontroller, and partner degree electronic circuit for interfacing with the sensors relate degreed a vitality supply, normally electric battery or relate degree inserted kind of vitality social affair.

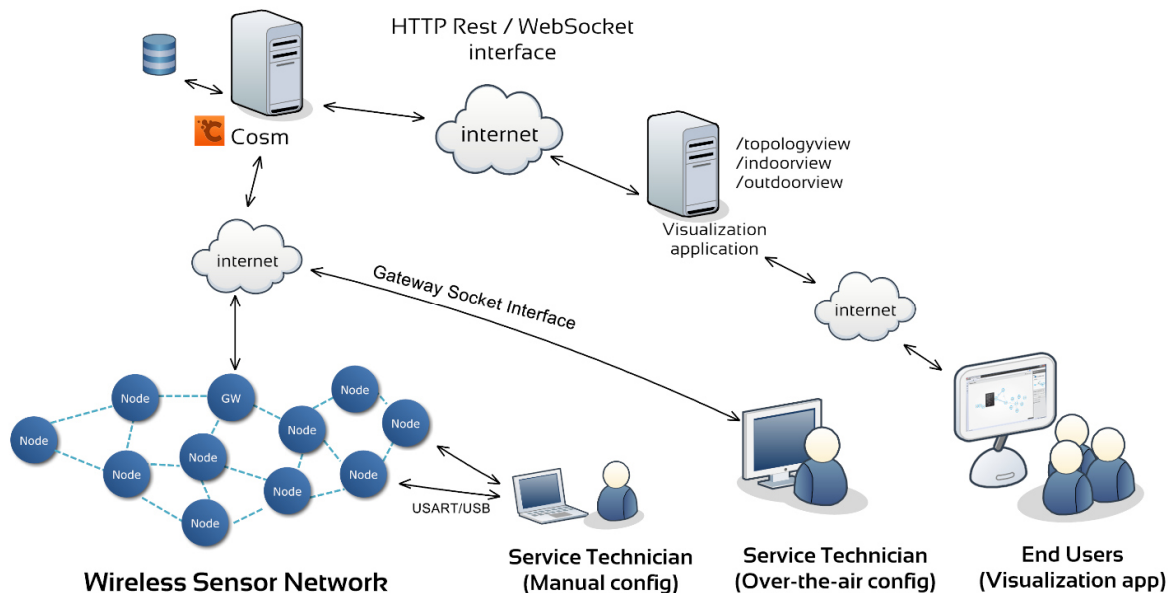

Fig. 1 - WSN Architecture

A wireless specially appointed network could be a limited sort of wireless network. The network is specially appointed as an aftereffect of it doesn't believe a previous framework, much the same as switches are display in wired networks or get to focuses

are available in overseen (foundation) wireless networks. Rather than that each hub takes an interest in directing by sending information for other hubs, that the assurance of that hubs forward learning is framed powerfully on the possibility of network property. Furthermore to the exemplary directing, impromptu networks will utilize flooding for sending learning. an advertisement hoc network normally alludes to any arrangement of networks wherever all gadgets have break even with remaining on a network and are liberal to accompany the other specially appointed network gadget in connection change.

Because of the decentralized (specially appointed) nature, wireless impromptu networks are helpless against refusal of administration assaults (DoS) or appropriated refusal of administration assaults (DDoS), which is an endeavor to make a machine or network asset inaccessible to its planned client. Specialists have explored in this field to an incredible develops, and gave a long stream of arrangements. These arrangements can anticipate assaults on short-term network accessibility, yet they are not powerful if there should arise an occurrence of assaults that influence long haul network accessibility. Finish consumption of hubs' batteries is the most lasting DoS assaults, which is occasion of asset exhaustion assault where battery power is intrigued asset. These assaults are known as Vampire assaults.

These assaults are not quite the same as those of DoS, lessening of value (RoQ) and steering foundation assaults. They don't upset quick accessibility however work after some time to shutdown network totally. Vampire assault is characterized as the synthesis and transmission of message that causes a considerable measure of vitality to be devoured by the network than if a legit node (unaffected hub) transmitted a message of identical size to indistinguishable goal, however abuse entirely unexpected bundle headers. The quality of assault can be measured by the proportion of network vitality utilized as a part of the ordinary case to the vitality utilized as a part of pernicious case. In the protected and safe instance of vampire assault, the proportion

is Vitality utilization of pernicious hub is not considered, as they can simply deplete their own batteries singularly.

## 2. VAMPIRE ATTACKS

Vampire assault [1] speak to of many assaults relying on convention kind. They're as per the following:

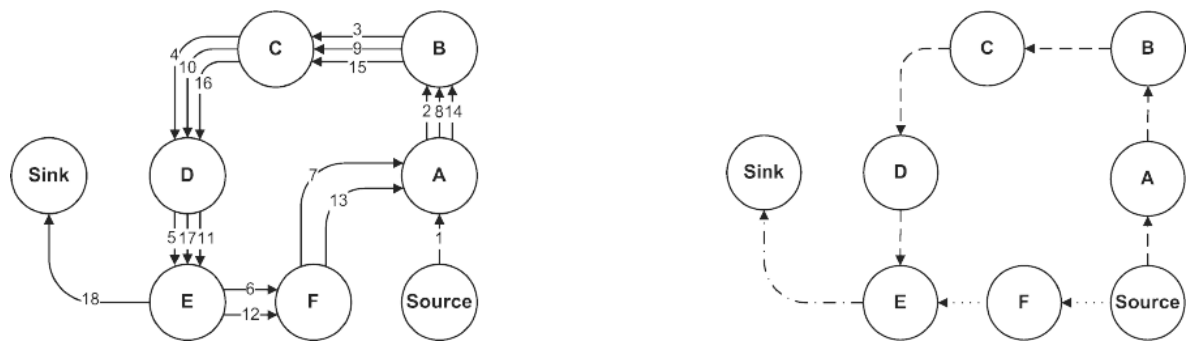

Fig. 2 - An illustration of Vampire Attack

- Directional receiving wire assault. Primary explanation for vampire assault is directional receiving wire assault. Vampires have almost no administration over bundle advance once sending decisions are made severally by each hub; be that as it may despite everything they'll squander vitality by restarting a bundle in fluctuated parts of the network.

There are 2 types of vampire assaults upheld this directional receiving wire assault. they're Extend assault and merry go round assault.

- Carousel Attack: In carousal assault, relate degree enemy forms bundles with deliberately presented steering circles. It targets supply directing conventions by

abusing the limited confirmation of message headers at sending hubs, allowing one bundle to over and again navigate indistinguishable arrangement of hubs.

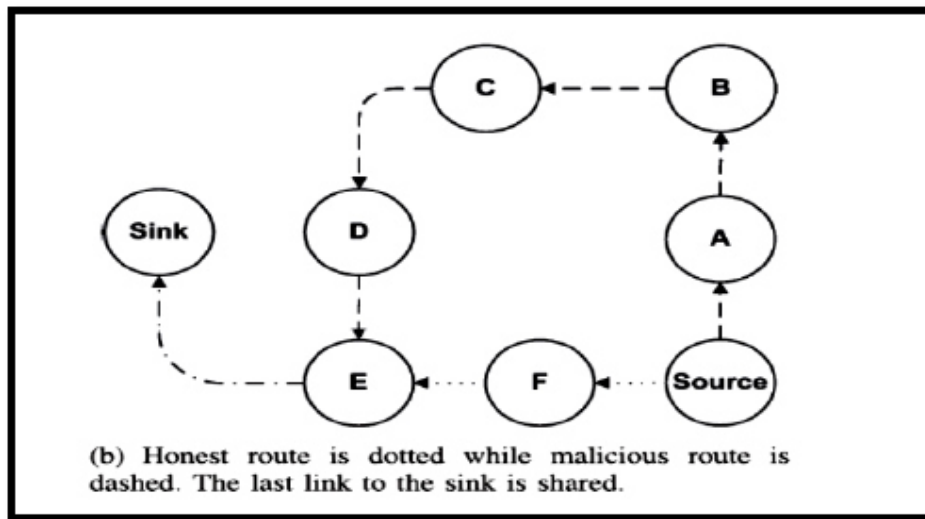

Fig. 3 - Carousal Attack Example

- Stretch assault: In Stretch assault, relate degree resister builds unnaturally long courses, possibly navigating every hub inside the network. It will expand bundle way lengths; exacting bundles to be handled by type of hubs that is independent of bounce compute the briefest way between the resister and bundle goal.

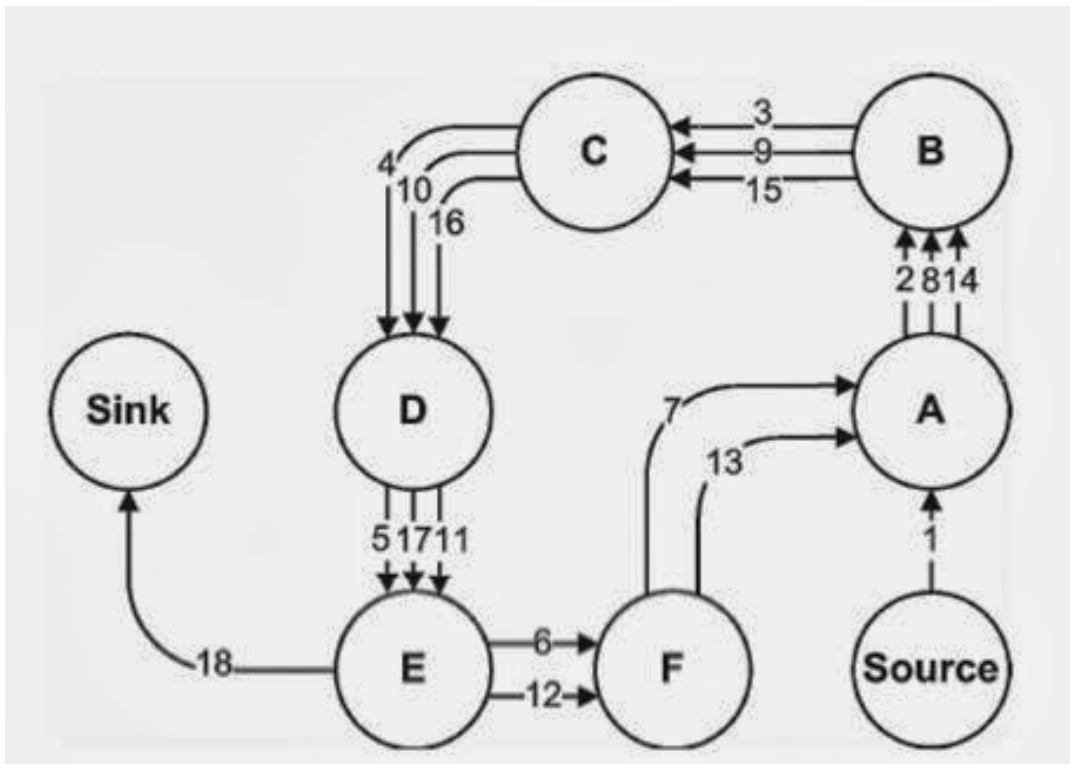

Fig. 4 - Example of Stretch Module Attack

• Malicious revelation assault. Another assault on all already said steering conventions (counting stateful and stateless) is spurious course revelation. In many conventions, every hub can forward course disclosure bundles (and for the most part course reactions as well), that implies it's capability to start a surge by causation one message. A spotless state secure identifier network directing convention is relate degree practical, greatly flexible to dynamic assaults. This convention [5] is presented by Bryan Parno, Check Luk, Evan Gaustad, Adrian Perrig (PLGP from here on).

It's 2 stages, they're topology disclosure segment and parcel sending segment. the primary form of the convention, despite the fact that intended for security, is helpless to vampire assaults. Here PLGP might be changed to evidently stand up to. Vampire assaults all through the parcel sending stage. PLGPa is that the convention that limits

damage from vampire assault, however this has numerous disadvantages. they're laid out beneath PLGPa incorporates way confirmations, expanding the measurements of every parcel, procurement punishments as far as data measure utilize, and in this manner radio power. Including extra bundle check necessities for moderate hubs conjointly will expand processor usage, requiring time, and additional power. Vitality use for cryptographical operations at middle of the road jumps is, plentiful bigger than transmit or get overhead, and far a considerable measure of stricken by the exact chipset usual develop the locator.whilePLGPa isn't helpless to vampire assaults all through the sending area, in any case it doesn't

#### **VAMPIRE ATTACK DETECTION**

There are two sorts of assaults in WSN, the steering exhaustion and asset consumption assault. The steering exhaustion assaults typically just influence the steering way the asset consumption assaults are the ones that assault the network highlights like data transmission, power, and vitality utilization. These assaults are ordinarily called as "Vampire assaults" [4]. They are called so since they empty the battery control out of the hubs. These are a kind of Denial of Service [2] since they influence the whole framework from performing. They are hard to be recognized since they are convention consistent and are orthogonal to them [5]. They are not convention particular. They don't influence a solitary hub they take their time assault one by one and upset the whole framework.

Vampire assaults can be characterized as the organization and transmission of a message that cause more vitality to be devoured by the network than if a legitimate hub transmitted a message of indistinguishable size to a similar goal, despite the fact that utilizing distinctive bundle headers. The quality of the assault is measured by the proportion of network vitality utilized as a part of the amiable case to the vitality utilized as a part of the noxious case.

Security from Vampire assaults suggests that this proportion is

1. Vitality use by vindictive hubs is not considered, since they can simply singularly deplete their own particular batteries.

A. Carousal assault In this assault, an enemy creates parcels with intentionally presented directing circles. It is called carousal assault, since it sends bundles in circles. It targets source directing conventions by abusing the constrained confirmation of message headers at sending hubs, permitting a solitary bundle to over and over again cross a similar arrangement of hubs. By and large, an arbitrary found merry go round assailant in the illustration specified topology can build the network vitality utilization by a variable of  $1.48 \pm 0.99$ .

The explanation behind this expansive standard deviation is that the assault does not generally build vitality utilization, the length of the antagonistic way is a various of the legitimate way, which is thusly, influenced by the position of the adversary's position of the foe in connection to the goal, so the adversary's position is vital to the accomplishment of this assault. Figure 4 demonstrates the network under assault where the parcels are sent in circles bringing about more use of vitality and time.

B. Extend assault In this assault, additionally focusing on source steering, a foe builds misleadingly long courses, possibly navigating each hub in the network. It is call this the extend assault, since it expands bundle way lengths, making parcels be handled by various hubs that is autonomous of jump number along the most limited way between the foe what's more, parcel goal. In the case topology, there is an expansion in vitality use by as much as an element of 10.5 for each message over the legit situation, with a normal increments in vitality utilization of  $2.67 \pm 2.49$ .

Similarly as with the merry go round assault, the explanation behind the vast standard deviation is that the position of the antagonistic hub influences the quality of the assault. Not all courses can be altogether protracted, contingent upon the area of the enemy. Not at all like the merry go round assault, where the relative places of the source and sink are essential, the extend assault can accomplish a similar adequacy



free of the attacker's network position with respect to the goal, so the most pessimistic scenario impact is much more prone to happen.

The effect of these assaults can be further expanded by consolidating them, expanding the quantity of ill-disposed hubs in the network, or just sending more parcels. In spite of the fact that in networks that don't utilize validation or just utilize end-to-end verification, enemies are allowed to supplant courses in any overhead parcels, we accept that lone messages began by enemies may have malignantly created courses.

## **CONCLUSION**

In this paper, the steering convention influenced by vampire assault in WSN is talked about. This is another class of asset utilization assault that utilization steering conventions to for all time impair specially appointed WSNs by exhausting node's battery control. Reenactment comes about demonstrate that relying upon the area of foe, network vitality consumption amid the sending stage expanding. The security imperfections of AODV can be settled by utilizing RSA encryption framework that will stay away from the foe from entering the framework. A full arrangement is not yet planned and the safeguards for topology revelation and in addition taking care of portable networks, is left for future work.

## **REFERENCES**

- [1] "The Network Simulator- ns-2" <http://www.isi.edu/nsnam/ns>.2012.
- [2] A. Wood and J.Stankovic.Denial of Service in sensor networks. IEEE Computer, pages 54-62, Oct, 2002.
- [3] A.Perrig, R.Szewczyk, J. D.Tygar, V. Wen, and D. E. Culler, "SPINS: Security protocols for sensor networks." *WirelessNetworks*, vol. 8, no. 5, pp. 521–534, 2002.

[4] Eugene Y.Vassermann and Nicholas Hopper “Vampire Attacks: Draining Life from Wireless Ad Hoc Sensor Networks”IEEE Trans. Mobile Computing, vol. 12, no. 2, pp. 318-332 Feb-2013.

[5] B.Przydatek, D. Song, and A.Perrig.SIA:Secure information aggregation in sensor network.In ACM SenSys, Nov2003.